



MANTEGNA

eurolflex A TOUCH OF SHADE

Tenda a bracci con cassonetto dal design distintivo a chiusura ermetica. Ha un'inclinazione continua da zero a ottantatré gradi e può essere agganciata direttamente o con staffe indipendenti sia a muro che a parete. Il supporto braccio laterale è fisso. Si regola sia l'allineamento dei bracci all'interno del cassonetto che l'inclinazione del terminale.

Dimensioni massime: larghezza 600 cm e sporgenza 300 cm.

Hermetic cassette awning with folding arms that presents an unique design. It has a continuous inclination from zero to eighty-three degrees and it is possible to fix it directly to the wall or with independent brackets. The lateral support is fixed. It is possible to adjust the arms's alignment into the cassette and also the terminal bar's alignment.

Maximum dimensions: width 600 cm x projection 300 cm

Hermetische Kassettenmarkise mit Gelenkarmen, die ein einzigartiges Design aufweist. Sie hat eine stufenlose Neigung von null bis dreiundachtzig Grad und kann entweder direkt an der Wand oder mit unabhängigen Halterungen befestigt werden. Die seitliche Stütze ist fest. Es ist möglich, die Ausrichtung der Arme in der Kassette und auch die Ausrichtung der Endleiste einzustellen.

Maximale Abmessungen: Breite 600 cm x Ausladung 300 cm

Store à cassette hermétique avec bras qui présente une conception unique. Il a une inclinaison continue de zéro à quatre-vingt-trois degrés et il est possible de la fixer directement au mur ou avec de supports indépendants. Le support latéral est fixe. Il est possible de régler l'alignement des bras dans le cassette ainsi que l'alignement de la barre terminale.

Dimensions maximales : largeur 600 cm x avancée 300 cm

Toldo com braços com cajón de cierre hermético que presenta un diseño único. Tiene una inclinación continua de cero a ochenta y tres grados y se puede fijar directamente a la pared o con soportes independientes. El soporte lateral es fijo. Es posible ajustar la alineación de los brazos en el casete y también la alineación de la barra terminal.

Dimensiones máximas: ancho 600 cm x salida 300 cm

Toldo com braços e caixote com fechamento hermético que apresenta um design único. Tem uma inclinação contínua de zero a oitenta e três graus e é possível fixá-lo diretamente à parede ou com suportes independentes. O suporte lateral é fixo. É possível ajustar o alinhamento dos braços na cassete e também o alinhamento da barra terminal.

Dimensões máximas: largura 600 cm x saliência 300 cm

MANTEGNA



sporgenza max | max projection | maximale Ausladung
avancée maximale | salida máx | saliência máxima

300 cm

AVAILABLE COLOURS

RAL	9010	7035	1013	ANTRACITE
-----	------	------	------	-----------



ANTHRACITE COLOUR
only with 600 cm profiles and galaxy plus arm



La Camera degli Sposi
torrione del Castello di San Giorgio, Mantova
Andrea Mantegna, 1431-1506

AWNING MINIMUM WIDTH

sporgenza braccio arm projection Arm Ausladung avancée du bras salida brazo saliência braço	larghezza tenda minima » 1 coppia bracci awning minimum width » 1 pair of arms Mindestbreite » 1 Paar von Armen largeur minimum store » 1 paire de bras ancho mínimo toldo » 1 par de brazos largura mínima de toldo com um par de braços
--	--

150	196 cm
175	221 cm
200	245 cm
225	269 cm
250	296 cm
275	315 cm
300	339 cm

WIND RESISTANCE CLASS ACCORDING TO THE EUROPEAN STANDARD UNI EN 13561

Classe di resistenza al vento secondo la normativa europea UNI EN 13561
 Wind resistance class according to the European standard UNI EN 13561
 Windwiderstandsklasse nach der Europäischen Norm EN 13561

Classe de résistance au vent conformément à la réglementation européenne UNI EN 13561
 Clase de resistencia al viento según la Normativa Europea UNI EN 13561
 Classe de resistência ao vento de acordo com as normas europeias UNI EN 13561

larghezza width Breite largeur ancho largura	sporgenza tenda aperta open awning projection Ausladung geöffnete Markise avancée store ouvert salida toldo abierto saliência toldo aberto	classe class Klasse classe clase classe	tubo avvolgitore roller tube Tuchwelle tube enrouleur tubo de enrollar tubo enrolador
600 cm 600 cm	300 cm 200 cm	1 2	Ø 70 Ø 70

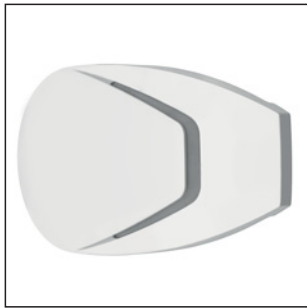

aluminium cassette cover

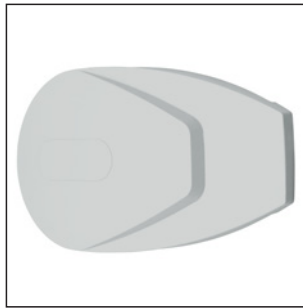

PVC cassette cover



terminal bar end cover

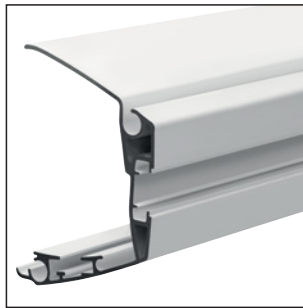

terminal bar



cassette lower profile



cassette upper profile

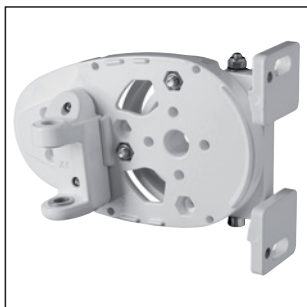

arm support



giotto extension

ARM LENGTH AND INCLINATION

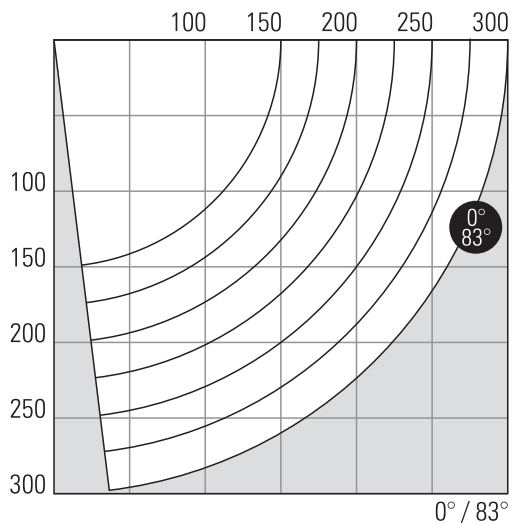

CONTINUOUS ADJUSTMENT

0° - 83° STAR
 regolazione continua
 continuous adjustment
 Kontinuierliche Einstellung
 réglage en continue
 ajuste continuo
 ajuste continuo

MAIN ARM

SP. MAX

300 cm

OPTIONAL ARM

SP. MAX

GALAXY PLUS	300 cm
ARIES	300 cm
ARIES PLUS	300 cm
STAR PLUS	300 cm
PEGASUS	300 cm
PEGASUS PLUS	300 cm
CASSIOPEA	300 cm
CASSIOPEA LED	300 cm
HERCULES	250 cm
SAGITTARIO	250 cm
PHOENIX	250 cm
TIGRIS	250 cm

WALL/CEILING BRACKET

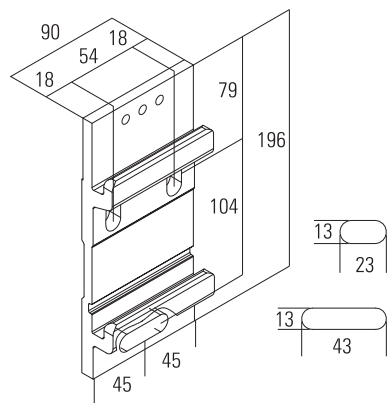

AWNING SIZES

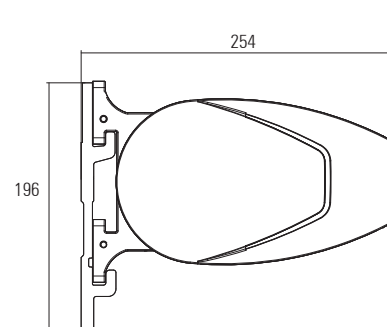

AWNING SIZES

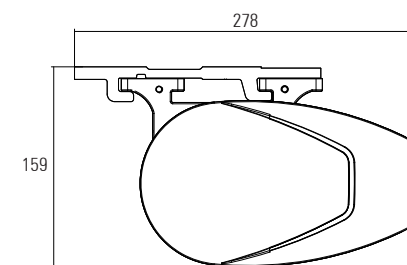

LED SYSTEM

PAGE 330



LED