

DONATELLO

eurolflex A TOUCH OF SHADE

Tenda a bracci in cassonetto a chiusura ermetica con supporti braccio a posizionamento intermedio. Ha un sistema di regolazione dell'inclinazione brevettato che permette una rotazione di 80°. Ha la possibilità di regolare l'allineamento dei bracci all'interno del cassonetto e di regolare l'inclinazione del terminale. Ha sporgenza massima di 400 cm e possibilità di giunzione tra più moduli.

Hermetically closed cassette awning with folding arms and with intermediary positioning of arm supports. It has a patented regulation of the inclination which enables the awning to obtain a 80° rotation. It offers the possibility to adjust the arms' alignment inside the cassette, together with the front bar inclination. There is the possibility to join more modules in the width, for a maximum projection of 400 cm.

Gelenkarmmarkise mit hermetischer Kassette. Verfügt über zwischen-Armträger. Hat ein patentiertes System zur Einstellung der Neigung, dass eine Drehung um 80° ermöglicht. Bietet die Möglichkeit an, die Angleichung der Arme innerhalb der Kassette zusammen mit der Neigung vom Endprofil zu justieren. Kann eine maximale Ausladung von 400 cm erreichen, und ermöglicht die Verbindung zwischen mehreren Modulen.

Store avec coffre à fermeture hermétique avec bras articulés et un positionnement intermédiaire des supports de bras. Il dispose d'un réglage de l'inclinaison breveté, qui permet au store d'obtenir une rotation de 80°. Il est possible d'ajuster l'alignement des bras à l'intérieur du coffre, ainsi que l'alignement du profil terminal. Il existe la possibilité de joindre plusieurs modules en largeur, pour une projection maximale de 400 cm.

Toldo con brazos con cajón de cierre hermético. Soporte brazo con posición intermedia. Su sistema de regulación de la inclinación es patentado y permite una rotación de 80°. Hay la posibilidad de ajustar la alineación de los brazos al interior del cajón y la de elegir la inclinación de la barra de carga. Es posible juntar múltiples módulos en la anchura, por una salida máxima de 400 cm.

Toldo com box de fechamento hermético para os braços com suporte de braços em posição intermediária. Possui um sistema de regulagem de inclinação patentado, o qual permite uma rotação de 80°. Existe a possibilidade de regular o alinhamento dos braços por dentro do box e de regular a inclinação do perfil terminal. Tem saliência máxima de 400 cm e é possível juntar mais módulos.

DONATELLO



sporgenza max | max projection | maximale Ausladung
avancée maximale | salida máx | saliência máxima

400 cm

AVAILABLE COLOURS

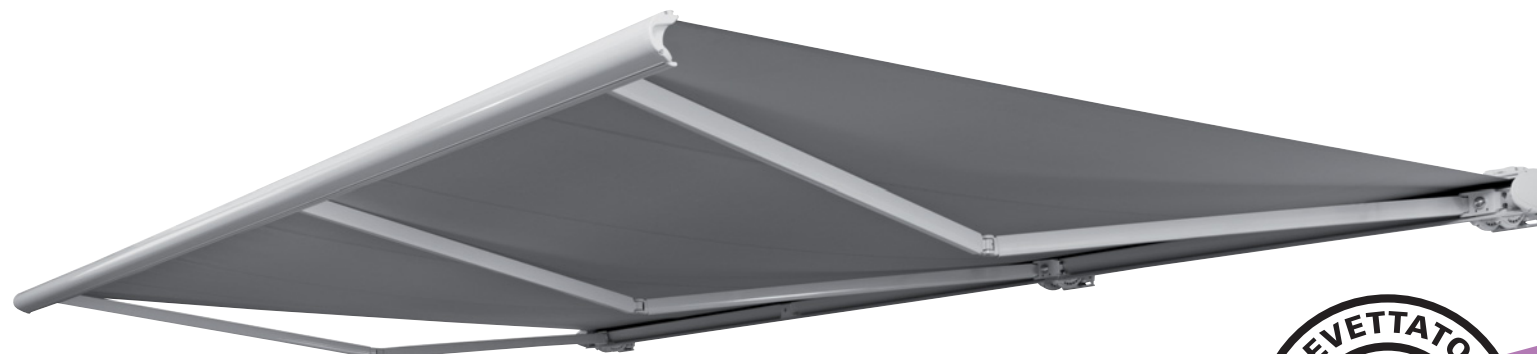

Monumento equestre al Gattamelata
Piazza del Santo, Padova
Donatello, 1445-1453

ARM NUMBER TABLE TO BE INSTALLED ON DONATELLO AWNING

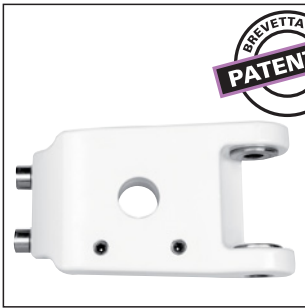

arm support



adjustable support & donatello rack



donatello internal support



cassette donatello

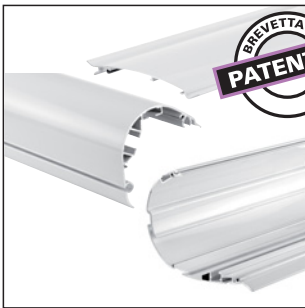

profiles

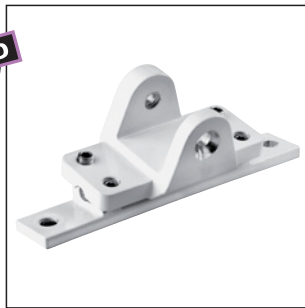

extension

ARM MODEL: DONATELLO	awning width arm projection	MINIMUM AWNING WIDTH (cm)*				AWNING WIDTH FROM (cm) TO (cm) suggested tube Ø 85 if width > 600 cm									
		with 2 arms	with 3 arms	with 4 arms	with 5 arms	0 / 600	601 / 623	624 / 659	660 / 694	695 / 770	771 / 850	851 / 869	870 / 917	918 / 1138	1139 / 1200
		200	277	400	524	647	2	3	3	3	3	3	4	4	4
225	301	436	572	707	2	3	3	3	3	3	4	4	4	5	
250	329	478	628	777	2	3	3	3	3	3	4	4	4	5	
275	353	514	676	837	2	3	3	3	3	3	4	4	4	5	
300	377	550	724	897	2	3	3	3	3	3	4	4	4	5	
325	401	586	772	957	2	3	3	3	3	3	4	4	4	5	
350	425	622	820	1017	2	●	3	3	3	3	4	4	4	5	
375	449	658	868	1077	2	●	●	3	3	3	●	4	4	5	
400	473	694	916	1137	2	●	●	●	3	3	●	●	4	5	

! N° ARMS	
WIDTH > 600 cm	3 ARMS
WIDTH > 850 cm	4 ARMS
WIDTH > 1140 cm	5 ARMS

● not possible

WIND RESISTANCE CLASS ACCORDING TO THE EUROPEAN STANDARD UNI EN 13561

Classe di resistenza al vento secondo la normativa europea UNI EN 13561
 Wind resistance class according to the European standard UNI EN 13561
 Windwiderstandsklasse nach der Europäischen Norm EN 13561

Classe de résistance au vent conformément à la réglementation européenne UNI EN 13561
 Clase de resistencia al viento según la Normativa Europea UNI EN 13561
 Classe de resistência ao vento de acordo com as normas europeias UNI EN 13561

width	open awning projection	class	roller tube
600 cm	400 cm	1	Ø 78
600 cm	350 cm	2	Ø 78

DONATELLO

ARM LENGTH AND INCLINATION

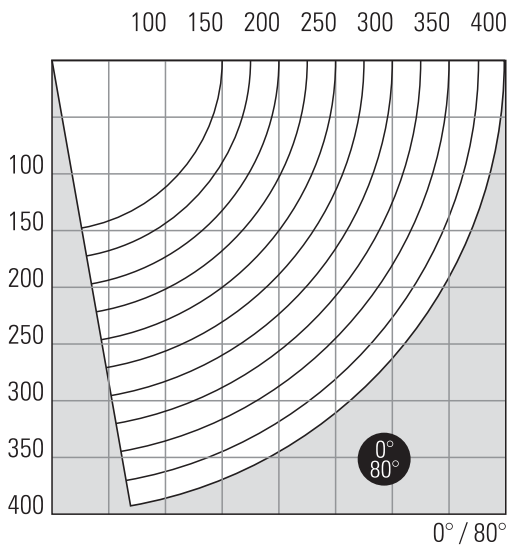

CONTINUOUS ADJUSTMENT

0° - 80°

regolazione continua
 continuous adjustment
 Kontinuierliche Einstellung
 réglage en continue
 ajuste continuo
 ajuste continuo

MAIN ARM

DONATELLO

SP. MAX

400 cm

WALL/CEILING BRACKET

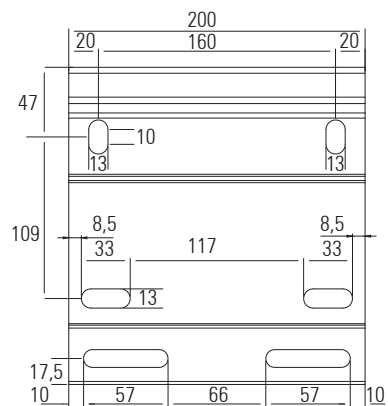

AWNING SIZES

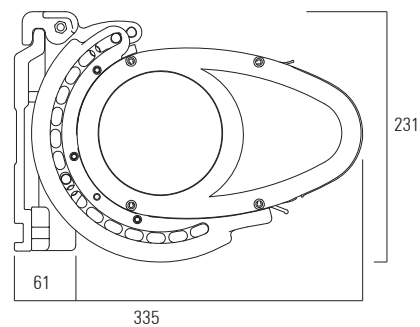

AWNING SIZES

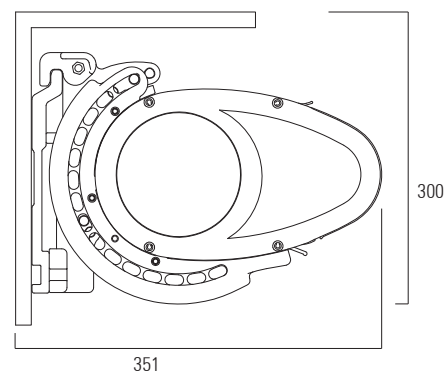

HOOD

PAGE 334



HO

