

SIGNORELLI 170

sporgenza max | max projection | maximale Ausladung
avancée maximale | salida máx | saliência máxima

425 cm



inclinazione braccio | arm angle | Arm Neigung
inclinaison du bras | inclinación del brazo | inclinaison du bras

170°



!
FREQUENT
COMPONENTS
ON PAGE 248

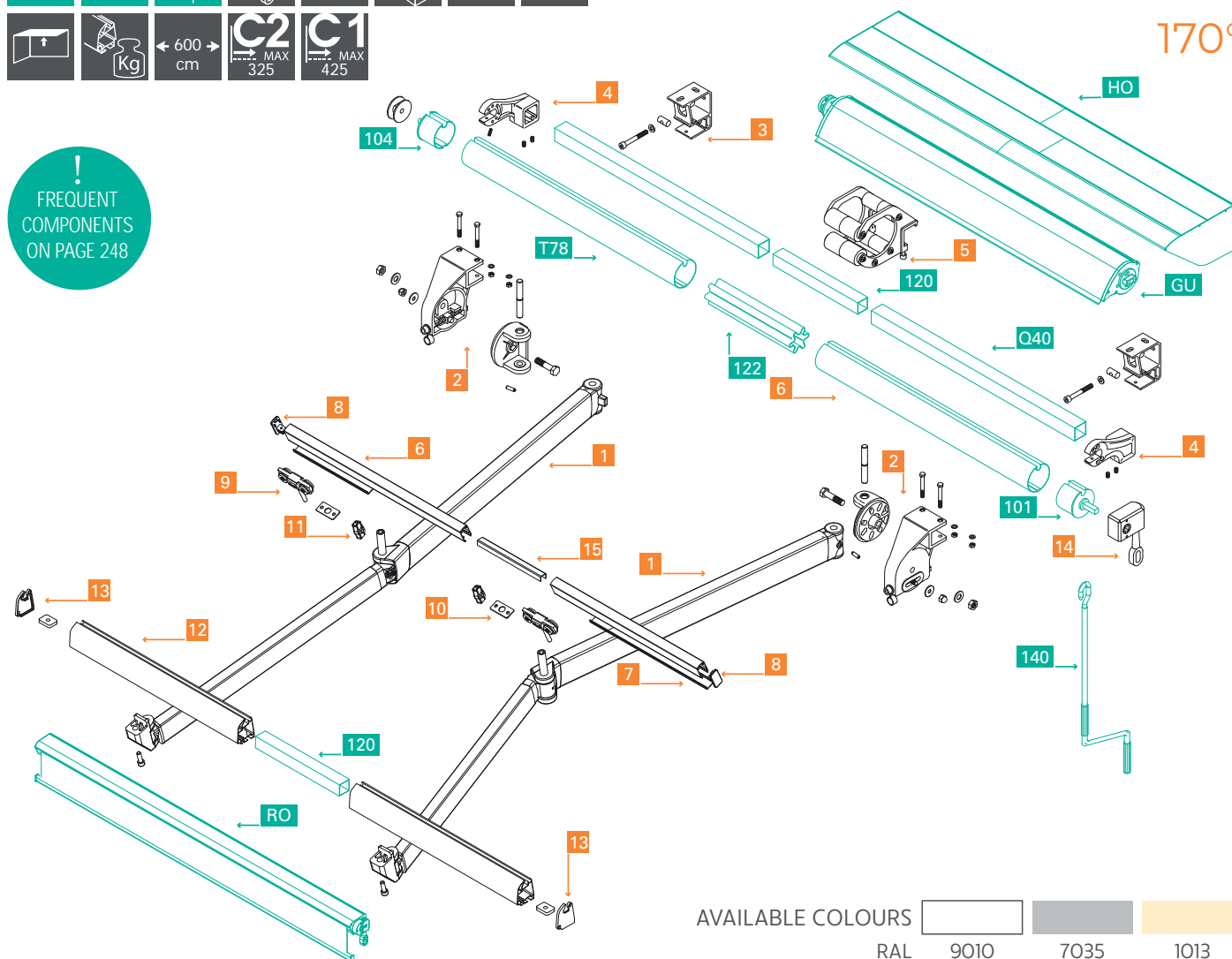













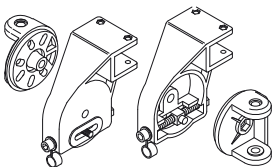
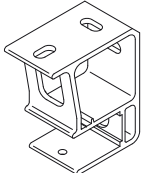
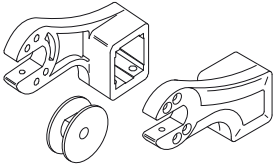
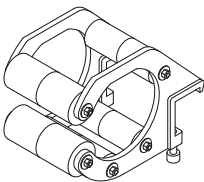
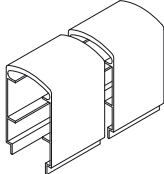
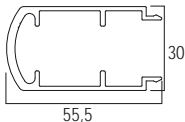
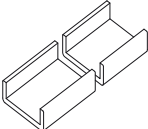
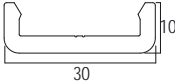
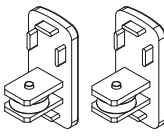
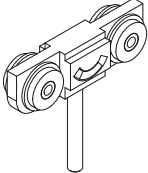
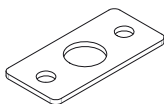
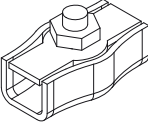

AVAILABLE COLOURS

RAL	9010	7035
		1013

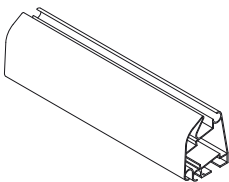
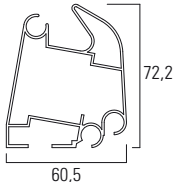

N°					
1		4XL250B 4XL275B 4XL300B 4XL325B 4XL350B 4XL375B 4XL400B 4XL425B	MAIN ARM braccio leonis inclinazione 170° leonis arm tilted of 170° Leonis Arm 170° Neigung bras leonis inclinaison 170° brazo leonis inclinación 170° braço leonis inclinação 170°	250 cm 275 cm 300 cm 325 cm 350 cm 375 cm 400 cm 425 cm	1 CP

N°						
2		4XL902ST/D	supporto braccio bernini con disco bernini arm support with disk Armträger Bernini mit Scheibe support bras bernini avec disque soporte brazo bernini con disco suporte braço bernini com disco		1 CP	
3		2XL903B	staffa universale in estrusione extruded universal bracket Stranggepresste universale Konsole étrier de fixation universel en extrusion soporte universal en extrusión estribo universal em expulsão		1 PZ	
4		2XL906ST	supporto tubo avvolgitore raffaello raffaello roller tube support Tuchwellenträger Raffaello support tube enrouleur raffaello soporte tubo de enroll raffaello suporte tubo enrolador raffaello		1 CP	
5		4XL908G	supporto compensatore con ruote Ø 45 balance support with Ø 45 rollers Ausgleichsstütz mit Ø 45 Rollen support compensateur avec roues Ø 45 soporte de compensación con ruedas Ø 45 suporte compensador com rodas Ø 45		1 PZ	
6		EXBOTFRAL4000 EXBOTFRAL5000 EXBOTFRAL6000 EXBOTFRAL7000	profilo frangitratta botticelli botticelli intermediary profile Botticelli Zwischenprofil profil brise-vent botticelli perfil intermedio botticelli perfil quebra-percurso botticelli		400 cm 500 cm 600 cm 700 cm	1 PZ
7		EXBOTCHL6000	profilo chiusura frangitratta closing profile for intermediary profile Verschlussprofil für Zwischenprofil profil de fermeture brise-vent perfil de cierre intermedio perfil fechamento quebra-trato		600 cm	1 PZ
8		19XLTAP	tappi frangitratta botticelli botticelli intermediary profile cap Botticelli Zwischenprofil Verschlussdeckel bouchon brise-vent botticelli tapas perfil intermedio botticelli tampas quebra-trato botticelli		1 CP	
9		19XLCAR	carrello interno per rinvio corda internal small trolley for rope-return Inneres Wälzlager für den Seilrückzug chariot interne pour renvoi corde carro interno para retorno cuerda carrinho interno para devolução corda		1 PZ	
10		19XLPJA	piastrina con fori per corda plate with holes for rope Plättchen mit Seillöchern platinas avec trous pour corde placa con agujeros para cuerda plaqueta com furos para a corda		1 PZ	
11		19XLCAPCO	capocorda end rope Anschlussösen bloque corde extremo cuerda bloca-corda		1 PZ	

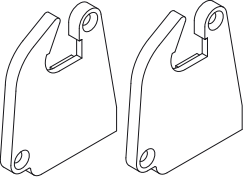
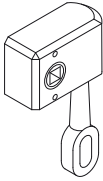
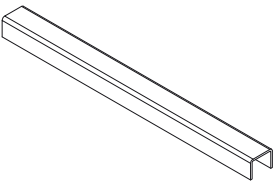
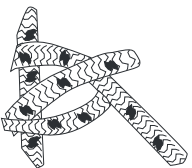
N°						
12		ESTRTPLUXL4000 ESTRTPLUXL5000 ESTRTPLUXL6000 ESTRTPLUXL7000	terminale pesante lux heavy lux terminal bar schweres Ausfallprofil Lux barre de charge lourde lux barra de carga pesada lux barra terminal pesado lux		400 cm 500 cm 600 cm 700 cm	1 PZ 
13		939TTLUX	tappo PVC terminale lux lux terminal bar PVC cap PVC Deckel für schwere Fallstange Lux bouchon PVC barre de charge lux tapa PVC barra de carga pesada lux tampa PVC barra terminal lux			1 CP
14		PFARG13/1	arganello 13/1 reduction winch 13/1 Wunsch 13/1 treuil 13/1 máquina sinfin 13/1 sarilho 13/1			1 PZ
15		19XLGIUN	giunzione frangitratta intermediary profile joint Verbindung für Zwischenprofil jonction pour brise-vent junta perfil intermedio junção quebra-trato			1 PZ
		19XLCOR3	corda Ø 3 mm rope Ø 3 mm Seil Ø 3 mm corde Ø 3 mm cuerda Ø 3 mm corda Ø 3 mm			1 ML

OPTIONAL

optional disponibili per questa tenda
extras available for this awning

vorhandene Möglichkeiten für diese Markise
options disponibles pour ce store



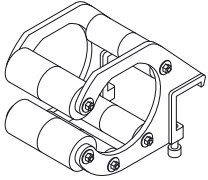
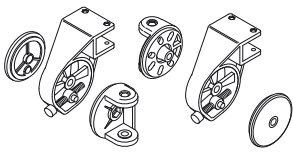
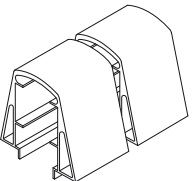
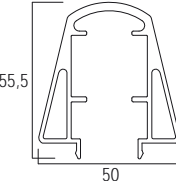

opciones disponibles para este toldo
opções disponíveis para este toldo

	4XL908P	supporto compensatore con ruote Ø 35 balance support with Ø 35 rollers Ausgleichsstütz mit Ø 35 Rollen support compensateur avec roues Ø 35 soporte de compensación con ruedas Ø 35 suporte compensador com rodas Ø 35			1 PZ
	4XL902/D	supporto braccio canova con dischi canova arm support with disks Armträger Canova mit doppel Scheibe support bras canova avec disques soporte brazo canova con discos suporte braço canova com discos			1 PZ
	EXBOTFRPEL6000 EXBOTFRPEL7000	profilo frangitratta pesante botticelli botticelli heavy intermediary profile Botticelli Schweres Zwischenprofil profil brise-vent lourde botticelli perfil intermedio pesada botticelli perfil quebra-percurso pesado botticelli		600 cm 700 cm	1 PZ

N° ARMS/WALL SUPPORTS/COMPENSATORS

arm projection ↙ ↘ awning width	AWNING WIDTH FROM (cm) TO (cm)											
	0 / 600	601 / 620	621 / 655	656 / 695	696 / 860	861 / 880	881 / 930	931 / 1120	1121 / 1165	1166 / 1350	1351 / 1395	1396 / 1500
250	2	3	3	3	3	4	4	4	5	5	6	6
275	2	3	3	3	3	4	4	4	5	5	6	6
300	2	3	3	3	3	4	4	4	5	5	6	6
325	2	3	3	3	3	4	4	4	5	5	6	6
350	2	●	3	3	3	4	4	4	5	5	6	6
375	2	●	●	3	3	●	4	4	5	5	6	6
400	2	●	●	●	3	●	●	4	●	5	●	6
n° wall supports	6	6	7	7	9	9	9	11	12	14	14	15
n° ballance supports	1	2	2	2	2	4	4	4	4	4	4	4

MEASUREMENT CALCULATED BY PLACING THE ARM SUPPORT ON THE ROLLER SUPPORT					
arm projection	min. width x 2 arms	min. width x 3 arms	min. width x 4 arms	min. width x 5 arms	min. width x 6 arms
250	310	470	630	790	945
275	335	505	680	850	1020
300	360	545	730	915	1095
325	385	580	780	975	1170
350	410	621	830	1040	1245
375	435	651	881	1100	1320
400	460	696	931	1166	1396

N° ARMS	
WIDTH > 600 cm	 3 ARMS
WIDTH > 860 cm	 4 ARMS
WIDTH > 1120 cm	 5 ARMS
WIDTH > 1350 cm	 6 ARMS

● not possible



ALERT 1

per una migliore resa estetica è opportuno lasciare 100 cm tra i gomiti dei bracci quando sono chiusi

für ein besseres ästhetisches Ergebnis, pfehlen wir zwischen den Ellbogen der Arme, wenn sie geschlossen sind, 100 cm zu verlassen

para obtener el mejor resultado estético, se aconseja dejar 100 cm de distancia entre los codos de los brazos cuando están cerrados

in order to improve the aesthetics, it is ommended to leave 100 cm between the arm elbows when they are closed

pour un meilleur rendement esthétique du produit, il est conseillé de laisser 100 cm entre les coudes des bras quand ils sont fermés

para um melhor resultado estético é recomendável deixar 100 cm entre os cotovelos dos braços quando estão fechados



ALERT 2

attenzione a non far corrispondere la posizione della giunzione del frangitratta con lo scorrimento del carrello sul gomito del braccio

achtung: Passen Sie nicht die Kupplung der Zwischenprofil an das Gleiten des Wälzlager am Ellbogen des Arms an

atención: no haga coincidir la junción de unión de la barra intermedia con el deslizamiento del carro interno en el codo del brazo

pay attention: do not match the junction's part of the intermediary bar with the sliding of the trolley on the arm's elbow

attention: ne faire pas correspondre la partie de jonction de la barre intermédiaire avec le chariot interne sur le coude du bras

atenção: não combine a parte da junção da barra intermediária com o deslizamento do carrinho interno no cotovelo do braço