

MICHELANGELO A TOUCH OF SHADE

Tenda a bracci su doppia barra quadra 40x40 mm con supporto braccio a posizionamento laterale e intermedio. Dimensioni massime modulo singolo: larghezza 710 cm e sporgenza 550 cm.

Folding arm awning on 40x40 mm double square bar with lateral and intermediate arm supports installation. Single module maximum dimensions: 710 cm width and 550 cm projection.

Gelenkarm-Markise auf 40x40 mm doppelten Vierkant-Tragrohr mit seitlichem oder Zwischen-Armträger. Maximalgröße je einziges Modul: Breite 710 cm und Ausladung 550 cm.

Store à bras sur double barre carrée 40x40 mm avec support bras à positionnement latéral et intermédiaire. Dimensions maximales du module simple: largeur 710 cm et avancée 550 cm.

Toldos con brazos sobre doble barra cuadrada 40x40 mm, soporte brazo con posiciones lateral e intermedia. Dimensiones máximas módulo individual: ancho 710 cm y salida 550 cm.

Toldo com braços sobre barra quadrada 40x40 mm com suporte braço com posicionamento lateral e intermédio. Dimensões máximas modulo singular: largura 710 cm e saliência 550 cm.

MICHELANGELO



sporgenza max | max projection | maximale Ausladung
avancée maximale | salida máx | saliência máxima

550 cm

AVAILABLE COLOURS

RAL

9010

7035

1013

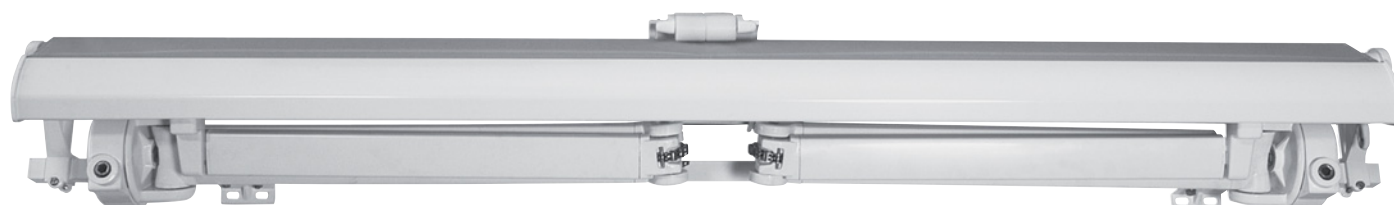

Schiavo morente - Museo del Louvre, Parigi
Michelangelo, 1501-1504

N° ARMS/WALL SUPPORTS/CENTRING/COMPENSATORS



arm support

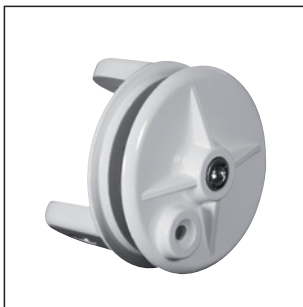

complete disk for arm support



roller tube support

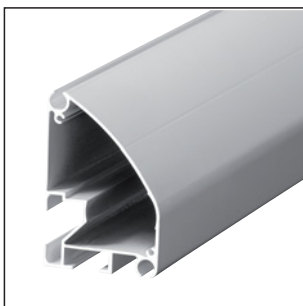

large terminal bar



terminal bar aluminium caps

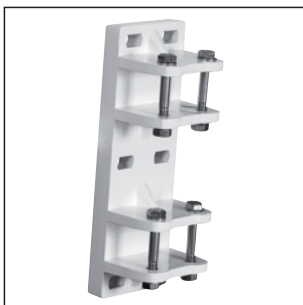

wall bracket



ceiling bracket

ARM AND POSSIBILITY DIMENSION FOR AWNING WIDTH FROM (cm) TO (cm)

awning width arm projection	0 / 710	711 / 748	749 / 822	823 / 895	896 / 1020	1021 / 1090	1091 / 1190	1191 / 1330	1331 / 1360	1361 / 1485	1486 / 1640	1641 / 1780	1781 / 1850
400	2	3	3	3	3	4	4	4	5	5	5	6	6
450	2	●	3	3	3	4	4	4	5	5	5	6	6
500	2	●	●	3	3	●	4	4	●	5	5	6	6
550	2	●	●	●	3	●	●	4	●	●	5	●	6
n° wall supp.	7	7	8	9	10	11	12	13	14	15	16	18	19
centring	/	✓	✓	✓	✓	✓	✓	✓	✓	✓	✓	✓	✓
n° balance supports	1	2	2	2	2	4	4	4	4	4	4	6	6

MEASUREMENT CALCULATED BY PLACING THE ARM SUPPORT ON THE ROLLER SUPPORT
to be applied in case of limit width

arm projection	min. width x 2 arms	min. width x 3 arms	min. width x 4 arms	min. width x 5 arms	min. width x 6 arms
400	451	672	892	1113	1333
450	501	747	992	1238	1483
500	551	822	1091	1361	1633
550	601	896	1191	1486	1781

N° ARMS	
WIDTH > 710 cm	3 ARMS
WIDTH > 1020 cm	4 ARMS
WIDTH > 1330 cm	5 ARMS
WIDTH > 1640 cm	6 ARMS

● not possible

WIND RESISTANCE CLASS ACCORDING TO THE EUROPEAN STANDARD UNI EN 13561

Classe di resistenza al vento secondo la normativa europea UNI EN 13561
Wind resistance class according to the European standard UNI EN 13561
Windwiderstandsklasse nach der Europäischen Norm EN 13561

Classe de résistance au vent conformément à la réglementation européenne UNI EN 13561
Clase de resistencia al viento según la Normativa Europea UNI EN 13561
Classe de resistència ao vento de acordo com as normas europeias UNI EN 13561

width	open awning projection	class	roller tube
710 cm	500 cm	1	Ø 78 mm

MICHELANGELO

ARM LENGTH AND INCLINATION

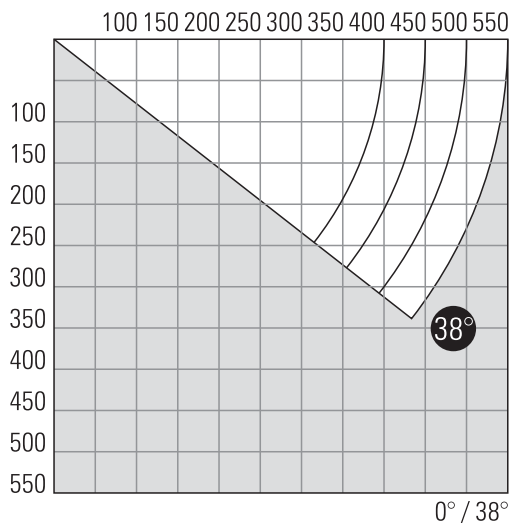

CONTINUOUS ADJUSTMENT

0° - 38°
 regolazione continua
 continuous adjustment
 Kontinuierliche Einstellung
 réglage en continue
 ajuste continuo
 ajuste continuo

MAIN ARM

ORION

SP. MAX

550 cm

WALL BRACKET

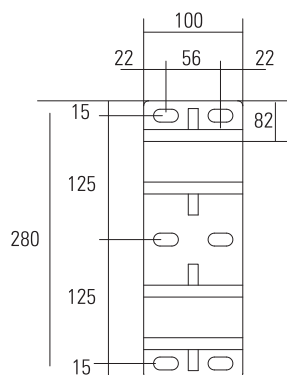

CEILING BRACKET

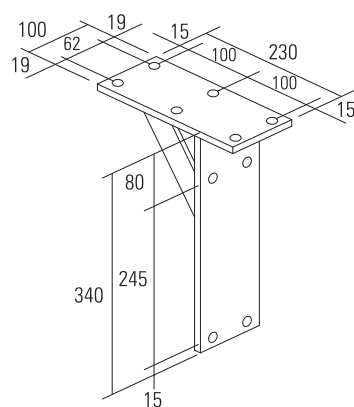

AWNING SIZES

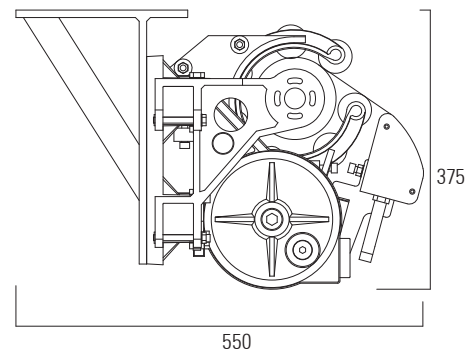

AWNING SIZES

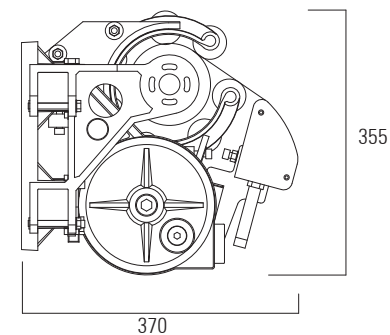

HOOD

PAGE 334



HO