

exclusive è Eccellenza

Exclusive è sinonimo di eccellenza ed esclusività. Un'eccellenza di prodotto che incomincia dalla qualità dei materiali utilizzati per forgiarlo: leghe di metalli con alte prestazioni meccaniche, di resistenza e di elasticità.

exclusive is Excellence

Exclusive represents both excellence and exclusivity. A product excellence which starts from the material quality used for the manufacturing to the metal alloys with high mechanical performances of resistance and elasticity.

exclusive ist Exzellenz

Exclusive ist Synonym von Exzellenz und Exklusivität. Die Exzellenz des Produktes stammt von der Qualität der benutzten Materialien: Metalllegierungen mit hohen mechanischen Leistungen, besonders in Haltbarkeit und Spannkraft.

exclusive c'est l'Excellence

Exclusive est synonyme d'excellence et d'exclusivité. Une excellence de produit qui commence par la qualité du matériel utilisé pour la fabrication, les alliages de métaux à hautes performances mécaniques de résistance et d'élasticité.

exclusive è Intelligenza

Exclusive è un insieme di prodotti di grande semplicità ed assoluta affidabilità. La ricerca e lo studio continuo di 40 anni di storia hanno dato vita a prodotti facili da assemblare e da posare, a componenti versatili che sanno semplificare i processi produttivi ed ottimizzare le scorte di magazzino.

exclusive is Intelligence

Exclusive is a range of simple products with an absolute reliability. With our 40 years experience in researches and studies we have developed products easy to assemble and to fix, as well as a variety of components which make easier the production process and the stock management.

exclusive ist Intelligenz

Exclusive besteht aus schlichten und vertrauenswürdigen Produkten. Der bemerkenswerte Erfahrungsschatz aus 40 Jahren Forschung hat einfach montierbare Produkte und vielseitige Einzelteile, die die Herstellung vereinfachen und die Lagerreserven optimieren, geschafft.

exclusive c'est l'Intelligence

Exclusive est un ensemble de produits de grande simplicité et de fiabilité absolue. La recherche et l'étude perpétuelle poursuivies depuis 40ans ont donné vie à des produits faciles à assembler et à poser, à des composants variés qui savent simplifier les processus de production et optimiser la gestion de stock.

exclusive è Qualità

La qualità si basa su prodotti di eccellenza ad elevate prestazioni; ma Exclusive è scegliere l'alta qualità di una relazione con un partner di grande affidabilità capace di far crescere il tuo business e di offrirti un servizio commerciale e tecnico a 360°.

exclusive is Quality

The quality bases itself on product excellence with high performances, but with Exclusive you choose a quality relationship with a reliable partner which will improve your business and provide you a technical and commercial service at 360°.

exclusive ist hochwertige Qualität

Die Qualität gründet sich auf hochwertige Produkte, die hohe Leistungen anbieten; mit Exclusive hat man aber auch einen vertraubaren Partner ausgesucht, der eine vollständige kommerzielle und technische Beratung anbietet und so Ihr Business steigen lässt.

exclusive c'est la Qualité

La qualité se base sur des produits d'excellence aux performances élevées, mais avec Exclusive c'est choisir la qualité d'une relation avec un partenaire de grande fiabilité capable de faire grandir votre business et de vous offrir un service technique et commercial à 360°.



exclusive è Stile

scegliere Exclusive significa entrare in un mondo di design innovativo. Significa imporre il proprio carattere, la propria personalità con linee e forme che si differenziano da ogni altro prodotto sul mercato.

exclusive is Style

Using Exclusive means entering in a world of innovative design and also means showing your own style and personality with lines and forms which are different from all other products of the market.

exclusive ist Stil

Exclusive bedeutet eine neue Welt mit einem erneuten Design. Mit Exclusive zeigt man Charakter und Persönlichkeit durch Linien und Formen, die sich von allen weiteren Produkten unterscheiden.

exclusive c'est le Style

Utiliser Exclusive signifie entrer dans un monde de design innovateur, signifie aussi imposer son propre style et personnalité avec des lignes et des formes qui se différencient de tous les autres produits du marché.

sistemi
componenti
accessori
per tende da sole

systems
components
accessories
for sun awnings

Systeme
Komponenten
Accessoires
für Markisen

systems
composants
accessoires
pour stores bannes



con arganello
with reduction winch
mit Kurbell
avec treuil



con motore
with motor
Mit Motor
avec moteur



modulare
modular
Modulierbar
moduler



Ø tubo avvolgitore
roller tube Ø
Tuchwelle Ø
tube enrouleur Ø



installazione parete
wall installation
Wandkonsole
dressage au mur



installazione soffitto
ceiling installation
Deckenkonsole
dressage plafond



installazione laterale
lateral installation
Nieschenkonsole
dressage latéral



terminale leggero
light terminal bar
Leichte Fallstange
barre de charge légère



terminale pesante
heavy terminal bar
Schwere Fallstange
barre de charge lourde



larghezza max cm
max width cm
Max Breite cm
largeur max cm



altezza max cm
max height cm
Max Höhe cm
hauteur max cm



sporgenza max cm
max projection cm
Max Ausladung cm
saillie max cm



classe 2: sporgenza max cm
class 2: max projection cm
Klasse 2: Max Ausladung cm
classe 2: saillie max cm



classe 1: sporgenza max cm
class 1: max projection cm
Klasse 1: Max Ausladung cm
classe 1: saillie max cm

TUTTE LE MISURE DEI BRACCI SONO INTESI PER SPORGENZA TENDA
ALL ARM DIMENSIONS ARE REFERRED TO THE AWNING PROTECTION
ALLE MASSE DER ARME VERSTEHEN SICH BEI VOLLER AUSBREITUNG DER MARKISE
TOUTES LES MESURES DES BRAS SONT ENTENDU POUR SAILLIE STORE

Legenda	<i>Legend</i>	Legende	<i>Légende</i>	008
 Tende a bracci su barra quadra	<i>Folding arm awnings on square bar</i>	Gelenkarmmarkisen mit Tragrohr	<i>Stores à bras en barre carrée</i>	010
 Tende a bracci con cassonetto	<i>Folding arm awnings with cassette</i>	Kassettenmarkisen	<i>Stores à bras avec coffre</i>	028
Gamma bracci	<i>Arm range</i>	Arme	<i>Gamme de bras</i>	034

T U R N F L E X B O O K

gira il catalogo e scopri la nuova gamma Euroflex

turn over the catalogue and discover the new Euroflex range

Blättern Sie die Preisliste durch und entdecken Sie die neue Produktpalette von Euroflex

feuilletez le catalogue et découvrez la nouvelle gamme Euroflex





tende a bracci su barra quadra

sporgenza max cm
max projection cm
Max Ausladung cm
saillie max cm

modigliani	012	350 cm
balla	016	350 cm
caravaggio	020	250 cm
marinetti	024	250 cm

folding arm awnings on square bar

Gelenkarmmarkisen mit Tragrohr

stores à bras en barre carrée



modigliani

Tenda a bracci su barra quadra 40x40 mm con supporto braccio a posizionamento laterale e intermedio.

Dimensioni massime modulo singolo: larghezza 600 cm e sporgenza 350 cm.

modigliani

Folding arm awning on 40x40 mm square bar with side and intermediate arm supports.

Single module maximum dimensions: 600 cm width and 350 cm projection.

modigliani

Gelenkarm Markise mit 40x40 mm Tragrohr mit seitlicher oder zwischen Armkonsolen.

Maximal Masse für Modul breite 600 cm und Ausladung 350 cm.

modigliani

Store à bras sur barre carrée 40x40 mm avec support bras à positionnement latéral et intermédiaire.

Dimensions maximums du module simple: largeur 600 cm et avancée 350 cm.



sporgenza max 350 cm

max projection 350 cm

Max Ausladung 350 cm

saille max 350 cm



braccio principale <i>main arm</i> Standart Arm <i>bras principal</i>	braccio opzionale <i>optional arm</i> Arm Option <i>bras en option</i>
galaxy plus	star plus star aries plus aries pegasus plus pegasus plus CT pegasus

sporgenza braccio <i>arm projection</i> Ausladung arme <i>saillie bras</i>	larghezza min. - 1 cp br <i>min. width - 1 pair arm</i> Min. Breite - 1 paar arme <i>largeur min. - 1 paire bras</i>	larghezza min. - 2 cp br <i>min. width - 2 pair arm</i> Min. Breite - 2 paar arme <i>largeur min. - 2 paire bras</i>
150	192 cm	380 cm
175	216 cm	428 cm
200	240 cm	476 cm
225	265 cm	525 cm
250	292 cm	580 cm
275	316 cm	628 cm
300	340 cm	676 cm
325	365 cm	725 cm
350	390 cm	774 cm

larghezza <i>width</i> Breite <i>largeur</i>	sporgenza tenda aperta <i>open awning projection</i> Ausladung geöffnete Markise <i>avancée store ouvert</i>	classe <i>class</i> Klasse <i>classe</i>	tubo avvolgitore <i>roller tube</i> Tuchwelle <i>tube enrouleur</i>
600 cm	350 cm	1	Ø 78 mm
600 cm	300 cm	2	Ø 78 mm

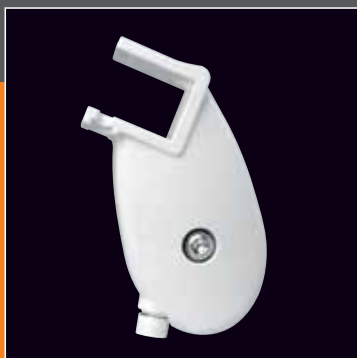

supporto braccio
arm support
Armkonsole
support bras



supporto braccio
arm support
Armkonsole
support bras

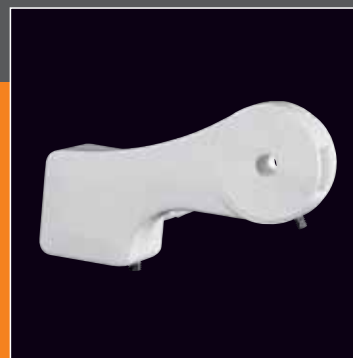

supporto tubo avvolgitore
roller tube support
Tuchwellenlager
support tube enrouleur



staffa universale
universal bracket
Universal Konsole
étrier de fixation universel

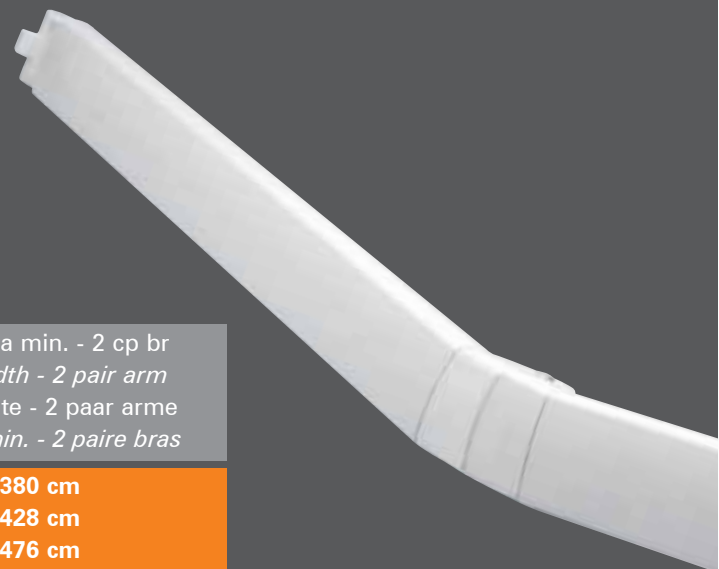



modigliani

sporgenza max 350 cm

max projection 350 cm

Max Ausladung 350 cm

saille max 350 cm

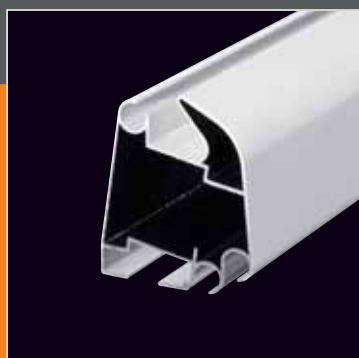
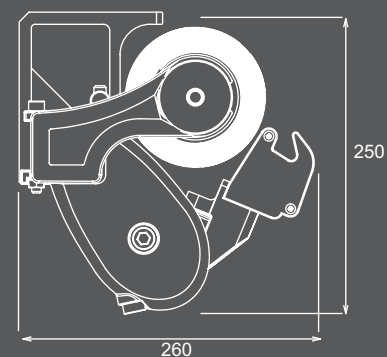
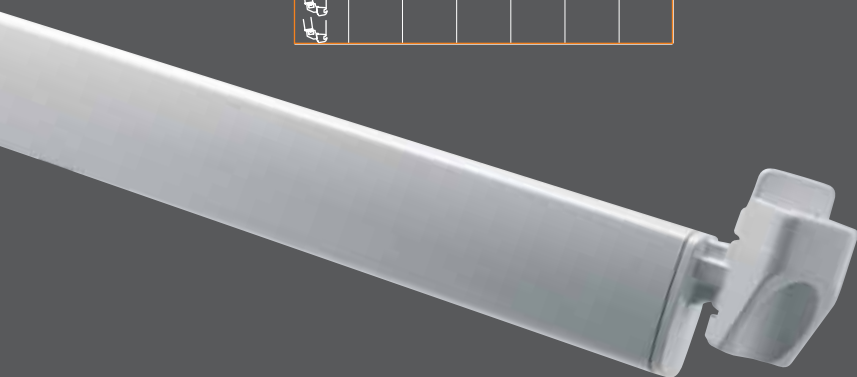
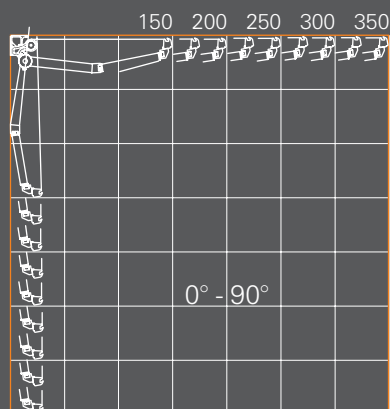

terminale pesante lux
heavy lux terminal bar
Fallstange Lux
barre de charge lourde lux

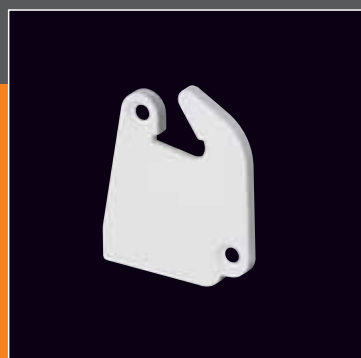

tappo PVC terminale pesante
PVC heavy terminal bar end cover
Fallstangendeckel PVC
bouchon PVC barre de charge lourde



supporto compensatore in nylon
nylon balance support
Stuetzlager PVC
support compensateur en nylon



staffa universale in estrusione
extruded universal bracket
Strangepresste Universal Konsole
étrier universel en extrusion



balla

Tenda a bracci su barra quadra 40x40 mm con supporto braccio a posizionamento laterale e intermedio.

Dimensioni massime modulo singolo: larghezza 600 cm e sporgenza 350 cm.

balla

Folding arm awning on 40x40 mm square bar with side and intermediate arm supports.

Single module maximum dimensions: 600 cm width and 350 cm projection.

balla

Gelenkarm Markise mit 40x40 mm Tragrohr mit seitlicher oder zwischen Armkonsolen.

Maximal Masse für Modul breite 600 cm und Ausladung 350 cm.

balla

Store à bras sur barre carrée 40x40 mm avec support bras à positionnement latéral et intermédiaire.

Dimensions maximums du module simple: largeur 600 cm et avancée 350 cm.



balla

sporgenza max 350 cm

max projection 350 cm

Max Ausladung 350 cm

saille max 350 cm



braccio principale <i>main arm</i> Standart Arm <i>bras principal</i>	braccio opzionale <i>optional arm</i> Arm Option <i>bras en option</i>
galaxy plus	star plus star aries plus aries pegasus plus pegasus plus CT pegasus

sporgenza braccio <i>arm projection</i> Ausladung arme <i>saillie bras</i>	larghezza min. - 1 cp br <i>min. width - 1 pair arm</i> Min. Breite - 1 paar arme <i>largeur min. - 1 paire bras</i>	larghezza min. - 2 cp br <i>min. width - 2 pair arm</i> Min. Breite - 2 paar arme <i>largeur min. - 2 paire bras</i>
150	192 cm	380 cm
175	216 cm	428 cm
200	240 cm	476 cm
225	265 cm	525 cm
250	292 cm	580 cm
275	316 cm	628 cm
300	340 cm	676 cm
325	365 cm	725 cm
350	390 cm	774 cm

larghezza <i>width</i> Breite <i>largeur</i>	sporgenza tenda aperta <i>open awning projection</i> Ausladung geöffnete Markise <i>avancée store ouvert</i>	classe <i>class</i> Klasse <i>classe</i>	tubo avvolgitore <i>roller tube</i> Tuchwelle <i>tube enrouleur</i>
600 cm	350 cm	1	Ø 78 mm
600 cm	300 cm	2	Ø 78 mm



supporto braccio
arm support
Armkonsole
support bras



supporto braccio
arm support
Armkonsole
support bras



supporto tubo avvolgitore
roller tube support
Tuchwellenlager
support tube enrouleur



staffa universale
universal bracket
Universal Konsole
étrier de fixation universel

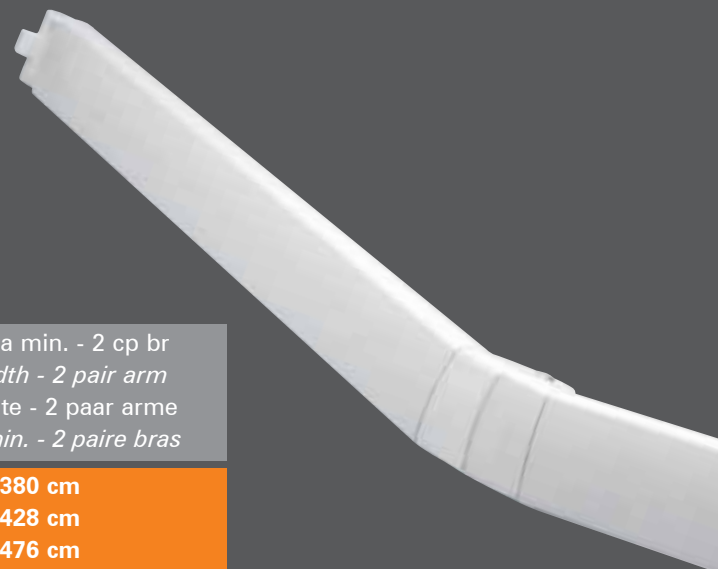

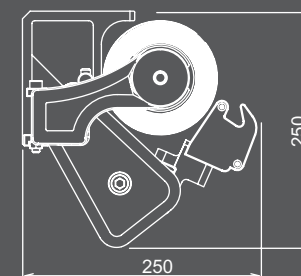
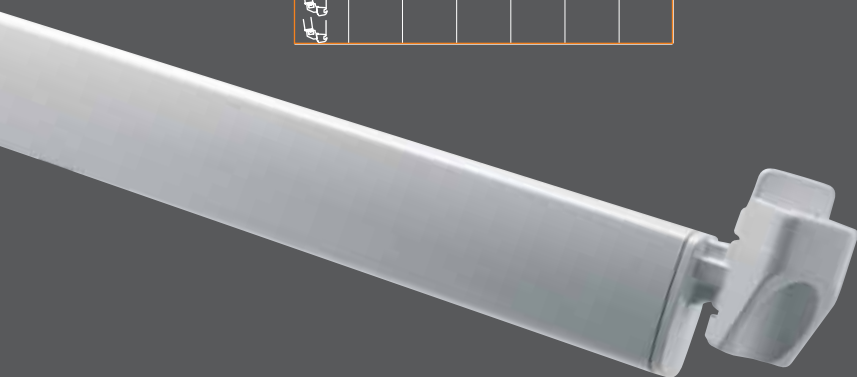
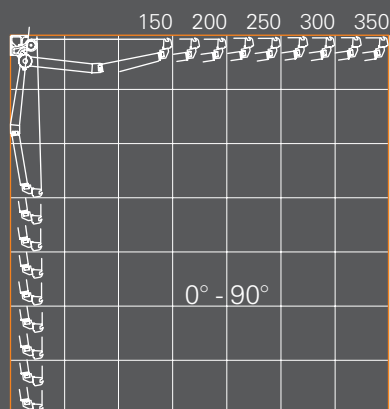

balla

sporgenza max 350 cm

max projection 350 cm

Max Ausladung 350 cm

saille max 350 cm

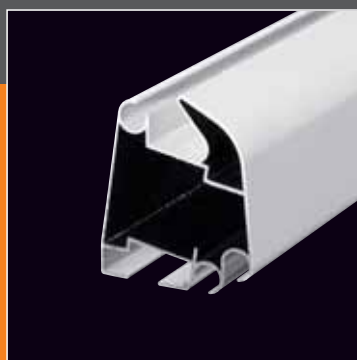

terminale pesante lux
heavy lux terminal bar
Fallstange Lux
barre de charge lourde lux

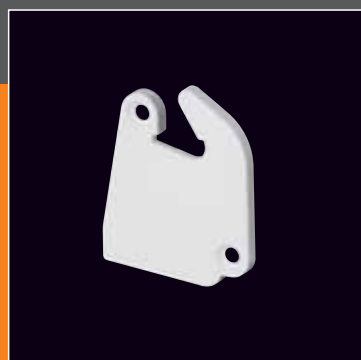

tappo PVC terminale pesante
PVC heavy terminal bar end cover
Fallstangendeckel PVC
bouchon PVC barre de charge lourde



supporto compensatore in nylon
nylon balance support
Stuetzlager PVC
support compensateur en nylon



staffa universale in estrusione
extruded universal bracket
Strangepresste Universal Konsole
étrier universel en extrusion



caravaggio

Tenda a bracci su barra quadra 40x40 mm con supporto braccio a posizionamento laterale e intermedio.

Dimensioni massime modulo singolo: larghezza 600 cm e sporgenza 250 cm.

caravaggio

Folding arm awning on 40x40 mm square bar with side and intermediate arm supports.

Single module maximum dimensions: 600 cm width and 250 cm projection.

caravaggio

Gelenkarm Markise mit 40x40 mm Tragrohr mit seitlicher oder zwischen Armkonsolen.

Maximal Masse für Modul breite 600 cm und Ausladung 250 cm.

caravaggio

Store à bras sur barre carrée 40x40 mm avec support bras à positionnement latéral et intermédiaire.

Dimensions maximums du module simple: largeur 600 cm et avancée 250 cm.



caravaggio

sporgenza max 250 cm

max projection 250 cm

Max Ausladung 250 cm

sailie max 250 cm



braccio principale <i>main arm</i> Standart Arm <i>bras principal</i>	braccio opzionale <i>optional arm</i> Arm Option <i>bras en option</i>
hercules	tigris phoenix gemini

sporgenza braccio <i>arm projection</i> Ausladung arme <i>saillie bras</i>	larghezza min. - 1 cp br <i>min. width - 1 pair arm</i> Min. Breite - 1 paar arme <i>largeur min. - 1 paire bras</i>
150	196 cm
175	220 cm
200	244 cm
225	268 cm
250	292 cm



larghezza <i>width</i> Breite <i>largeur</i>	sporgenza tenda aperta <i>open awning projection</i> Ausladung geöffnete Markise <i>avancée store ouvert</i>	classe <i>class</i> Klasse <i>classe</i>	tubo avvolgitore <i>roller tube</i> Tuchwelle <i>tube enrouleur</i>
600 cm	250 cm	1	Ø 70 mm
600 cm	225 cm	2	Ø 70 mm



supporto braccio
arm support
Armkonsole
support bras



supporto braccio
arm support
Armkonsole
support bras



supporto tubo avvolgitore
roller tube support
Tuchwellenlager
support tube enrouleur



staffa attacco universale
universal bracket
Universal Konsole
étrier de fixation universel



caravaggio

sporgenza max 250 cm

max projection 250 cm

Max Ausladung 250 cm

saille max 250 cm

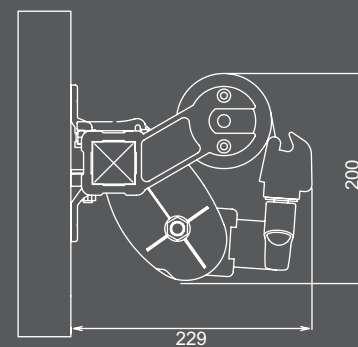
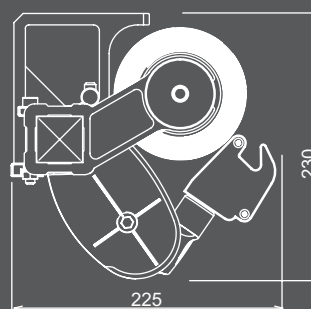
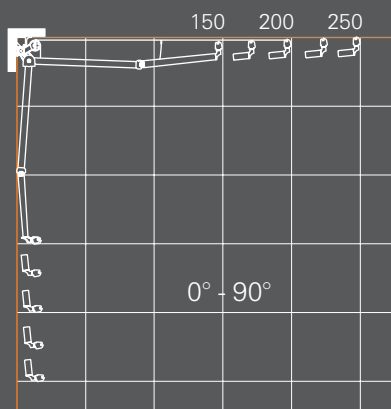

terminale leggero lux
light lux terminal bar
Leichte Fallstange Lux
barre de charge légère lux



tappo pvc terminale
terminal bar PVC end cover
Fallstangendeckel PVC
bouchon pvc barre de charge



perno raccoglibraccio
arm folding checkpin
Bolzen für Gelenkarm
pivot ramassage petit bras

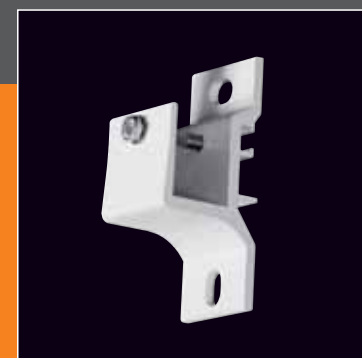

staffa parete/soffitto
wall/ceiling bracket
Wand/Deckenkonsole
étrier de fixation plafond/mural



marinetti

Tenda a bracci su barra quadra 40x40 mm con supporto braccio a posizionamento laterale e intermedio.

Dimensioni massime modulo singolo: larghezza 600 cm e sporgenza 250 cm.

marinetti

Folding arm awning on 40x40 mm square bar with side and intermediate arm supports.

Single module maximum dimensions: 600 cm width and 250 cm projection.

marinetti

Gelenkarm Markise mit 40x40 mm Tragrohr mit seitlicher oder zwischen Armkonsolen.

Maximal Masse für Modul breite 600 cm und Ausladung 250 cm.

marinetti

Store à bras sur barre carrée 40x40 mm avec support bras à positionnement latéral et intermédiaire.

Dimensions maximums du module simple: largeur 600 cm et avancée 250 cm.



sporgenza max 250 cm

max projection 250 cm

Max Ausladung 250 cm

sailie max 250 cm



braccio principale <i>main arm</i> Standart Arm <i>bras principal</i>	braccio opzionale <i>optional arm</i> Arm Option <i>bras en option</i>
--	---

hercules	tigris phoenix gemini
-----------------	--

sporgenza braccio <i>arm projection</i> Ausladung arme <i>saillie bras</i>	larghezza min. - 1 cp br <i>min. width - 1 pair arm</i> Min. Breite - 1 paar arme <i>largeur min. - 1 paire bras</i>
---	---

150	196 cm
175	220 cm
200	244 cm
225	268 cm
250	292 cm



larghezza <i>width</i> Breite <i>largeur</i>	sporgenza tenda aperta <i>open awning projection</i> Ausladung geöffnete Markise <i>avancée store ouvert</i>	classe <i>class</i> Klasse <i>classe</i>	tubo avvolgitore <i>roller tube</i> Tuchwelle <i>tube enrouleur</i>
600 cm	250 cm	1	Ø 70 mm
600 cm	200 cm	2	Ø 70 mm



supporto braccio
arm support
Armkonsole
support bras



supporto braccio
arm support
Armkonsole
support bras



supporto tubo avvolgitore
roller tube support
Tuchwellenlager
support tube enrouleur

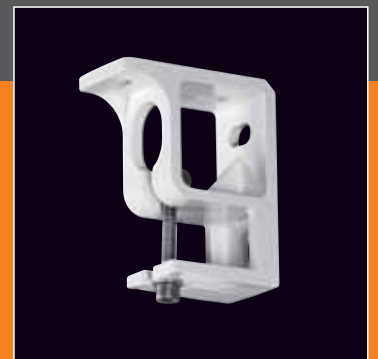

staffa attacco universale
universal bracket
Universal Konsole
étrier de fixation universel



marinetti

sporgenza max 250 cm

max projection 250 cm

Max Ausladung 250 cm

saille max 250 cm

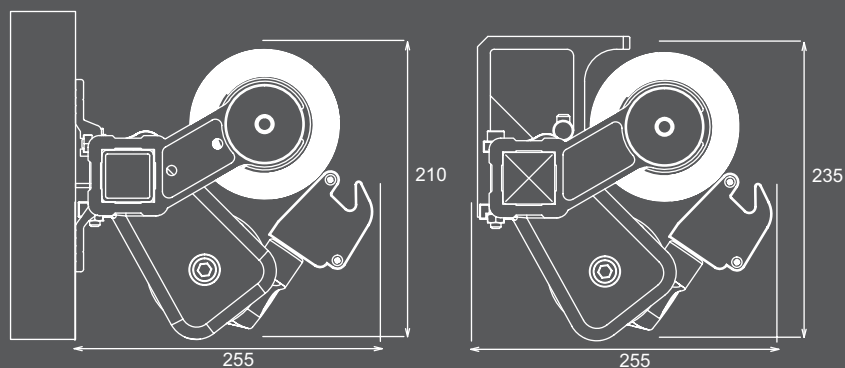
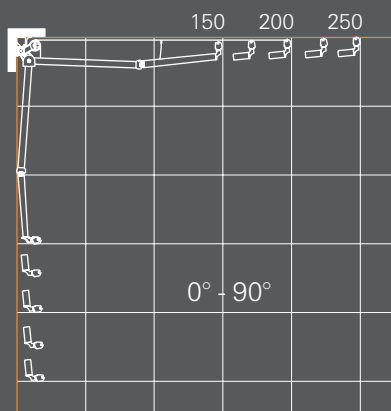

terminale leggero lux
light lux terminal bar
Leichte Fallstange Lux
barre de charge légère lux



tappo pvc terminale
terminal bar PVC end cover
Fallstangendeckel PVC
bouchon pvc barre de charge



perno raccoglibraccio
arm folding checkpin
Bolzen für Gelenkarm
pivot ramassage petit bras

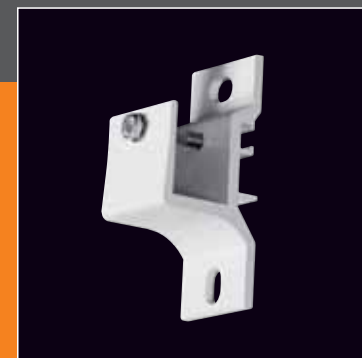

staffa parete/soffitto
wall/ceiling bracket
Wand/Deckenkonsole
étrier de fixation plafond/mural





tende a bracci con cassonetto

sporgenza max cm
max projection cm
Max Ausladung cm
saillie max cm

giotto

030

250 cm

folding arm awnings with cassette

Kassettenmarkisen

stores à bras avec coffre



giotto

Tenda a bracci con cassonetto a chiusura ermetica con supporto braccio laterale fisso. Può essere attaccata a muro direttamente o con staffe indipendenti. Possibilità di regolare l'allineamento dei bracci all'interno del cassonetto e di regolare l'inclinazione del terminale.

Dimensioni massime: larghezza 480 cm e sporgenza 250 cm.

giotto

Awning with arms and hermetically closed cassette with fixed side arm. It can be anchored directly to the wall or by means of separate brackets. Alignment of the arms inside the cassette and the angle of the end bar can be adjusted. Maximum dimensions: width 480 cm, protrusion 250 cm.

giotto

Geteilter Vorhang mit hermetisch verschlossenem Kasten und ortsfester seitlicher Kragarmhalterung. Kann direkt an der Wand oder mit unabhängigen Halterungen angebracht werden. Möglichkeit zur Korrektur der Kragarme innerhalb des Kastens und zur Einstellung der Neigung des Endstücks. Höchstabmessungen: Breite 480 cm und Auskrägung 250 cm.

giotto

Store à bras avec coffre hermétique et support de bras latéral fixe. Peut se monter au mur directement ou à l'aide d'étriers indépendants. Possibilité de régler l'alignement des bras à l'intérieur du coffre et de régler l'inclinaison de l'extrémité. Dimensions maximum : largeur 480 cm et saillie 250 cm



giotto

sporgenza max 250 cm

max projection 250 cm

Max Ausladung 250 cm

sailie max 250 cm

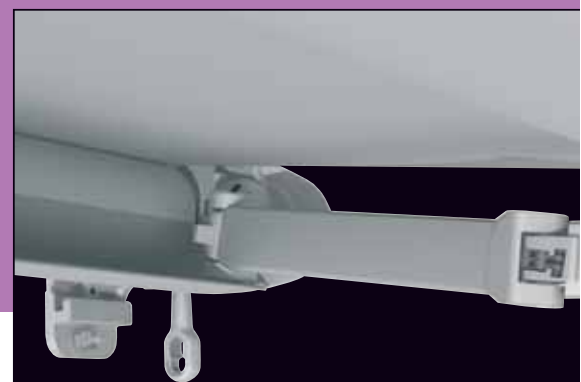
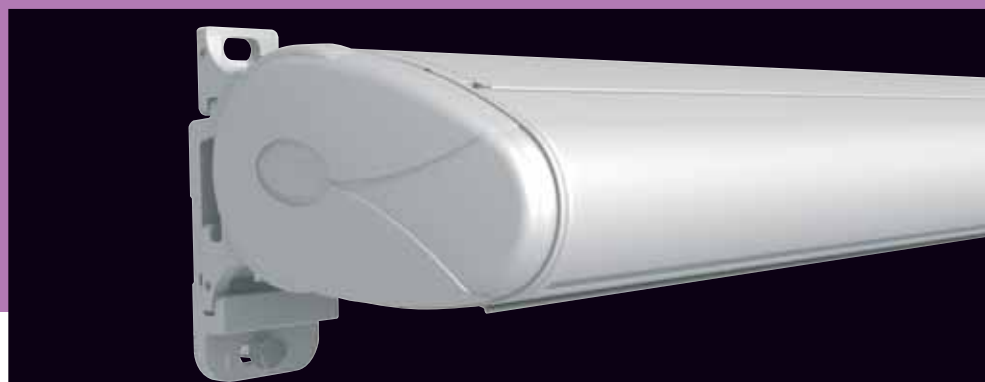

braccio principale <i>main arm</i> Standart Arm <i>bras principal</i>	braccio opzionale <i>optional arm</i> Arm Option <i>bras en option</i>
hercules	tigris phoenix gemini

sporgenza braccio <i>arm projection</i> Ausladung arme <i>saillie bras</i>	larghezza min. - 1 cp br <i>min. width - 1 pair arm</i> Min. Breite - 1 paar arme <i>largeur min. - 1 paire bras</i>
150	206 cm
175	230 cm
200	254 cm
225	278 cm
250	302 cm



larghezza <i>width</i> Breite <i>largeur</i>	sporgenza tenda aperta <i>open awning projection</i> Ausladung geöffnete Markise <i>avancée store ouvert</i>	classe <i>class</i> Klasse <i>classe</i>	tubo avvolgitore <i>roller tube</i> Tuchwelle <i>tube enrouleur</i>
480 cm	250 cm	1	Ø 70 mm
480 cm	200 cm	2	Ø 70 mm



supporto braccio
arm and cassette support
Armkonsole und Kassetten
support bras et coffre

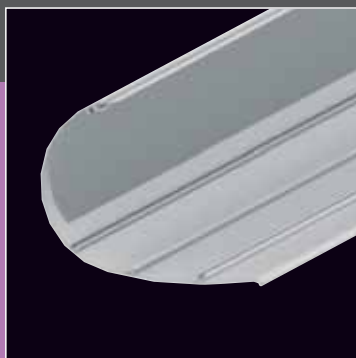

profilo cassettono inferiore
cassette lower profile
Unteres Kassettenprofil
profil inférieur coffre

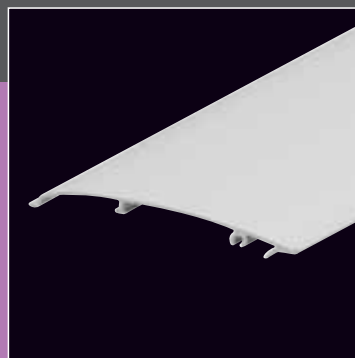

profilo cassettono superiore
cassette upper profile
Oberes Kassettenprofil
profil supérieur coffre



tappo cassettono
cassette end cover
Kassetten Deckel
bouchons coffre



giotto

sporgenza max 250 cm

max projection 250 cm

Max Ausladung 250 cm

sailie max 250 cm

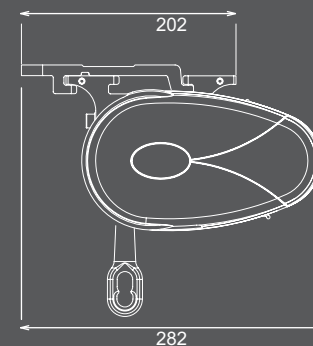
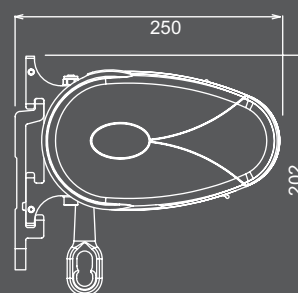
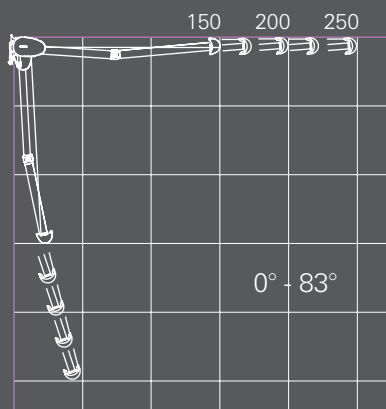

staffa parete/soffitto
wall/ceiling bracket

Wanddecken Konsole

étrier de fixation plafond/mural

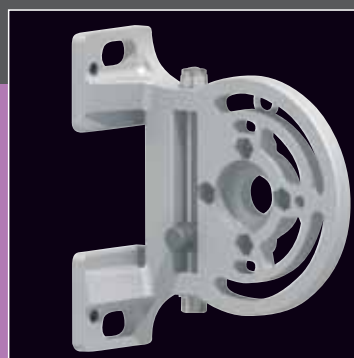

supporto
support
Konsole
support

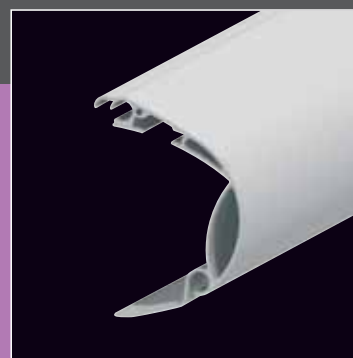

profilo terminale
terminal bar
Fallstangenprofil
barre de charge



tappo terminale
terminal bar end cover
Fallstangendeckel
bouchon barre de charge





gamma bracci

sporgenza max cm
max projection cm
Max Ausladung cm
saillie max cm

galaxy plus

036

350 cm

arm range

Gelenkarme

gamme de bras

galaxy plus

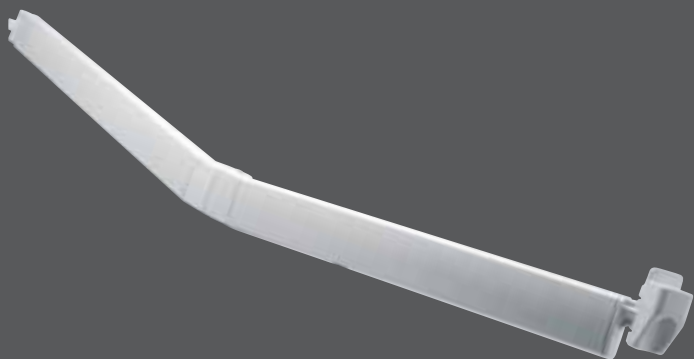

sporgenza tenda
awning projection
Ausladung Markise
avancée store

150 cm
175 cm
200 cm
225 cm
250 cm
275 cm
300 cm
325 cm
350 cm

disponibile per tenda
available for awning
Erhältlich für folgende Markisen
disponible pour store

raffaello
tiziano
modigliani
balla

tiepolo
giorgione
perugino

vasari

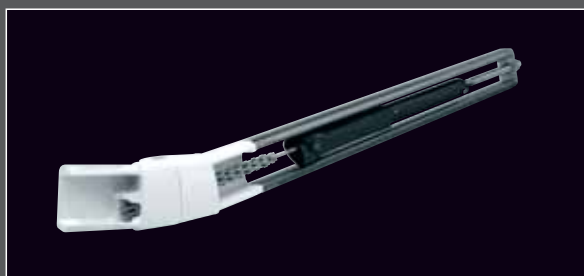

cartuccia
cartridge
Einsatz
cartouche

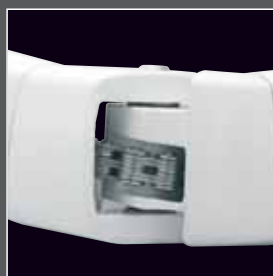

snodo
articulation
Artikulation
rotule



spalla
abutment
Leibung
épaule



profilo superiore
upper profile
Oberprofil
profil supérieur



puntale + prolunga
tip + extension
Spitze + Verlängerung
pointe + prolonge

A
TOUCH
OF
STYLE



T U R N F L E X B O O K

gira il catalogo e scopri la
nuova gamma Euroflex

*turn over the catalogue
and discover the new
Euroflex range*

Blättern Sie die Preisliste
durch und entdecken Sie
die neue Produktpalette
von Euroflex

*feuilletez le catalogue est
découvrez la nouvelle
gamme Euroflex*